



# Electric LULA

## Design and Planning Guide



**Please note:**

Dimensions provided in this Guide are for **REFERENCE ONLY** and should not be used for site preparation or construction.

# Table of Contents

<b>Elvoron MRL LULA</b> .....	<b>4</b>
<b>Hoistway Construction</b> .....	<b>5</b>
Wood Construction .....	6
Masonry Construction .....	6
Door Openings .....	6
<b>Construction of Pit:</b> .....	<b>7</b>
Pit Lighting .....	7
Overhead Clearance.....	7
Lifting Beam .....	7
<b>Loading Diagram</b> .....	<b>8</b>
<b>Car Sizes and Configurations</b> .....	<b>9</b>
<b>Layouts and Clearances</b> .....	<b>10</b>
Style 1L & 1R.....	10
Style 2 .....	13
Style 3 .....	16
Style 4 .....	17
<b>Operating Controls</b> .....	<b>18</b>
Car Operating Panel (COP) .....	18
Hall Stations .....	18
Car Direction Lantern.....	18
<b>Controller</b> .....	<b>19</b>
Electrical Disconnect.....	19
Ventilation Requirements .....	19
Mains Power Requirements.....	19
Emergency Battery Lowering.....	19
<b>Door Details</b> .....	<b>20</b>
Wood and Drywalls .....	20
Masonry Walls (with Controller in Door Buck) .....	22
<b>Technical Information</b> .....	<b>24</b>

# Electric LULA

The Electric LULA (Limited Use Limited Application) elevator is a cost effective way to transport the public from one landing to another. The Electric LULA elevator is a power passenger elevator in which the use and application is limited by size, capacity, speed and rise (see Technical Information for more details). The Electric LULA provides a code compliant automatic elevator with a variety of platform configurations and can service up to 6 landings. The wide selection of cab finishes and options ensure that it will blend into any setting. In addition, the Electric LULA with door buck controller option does not require a machine room for the elevator. The control cabinet can be installed on a landing adjacent to the landing door. This product also allows higher usage compared to the hydraulic drive system.

1. Motor with Gearbox
2. Headframe
3. Rail Brackets
4. Counterweight Guide Rail
5. Car Guide Rail
6. Lifting Bracket
7. Cantilever Arm
8. Counterweight
9. Pit Channel

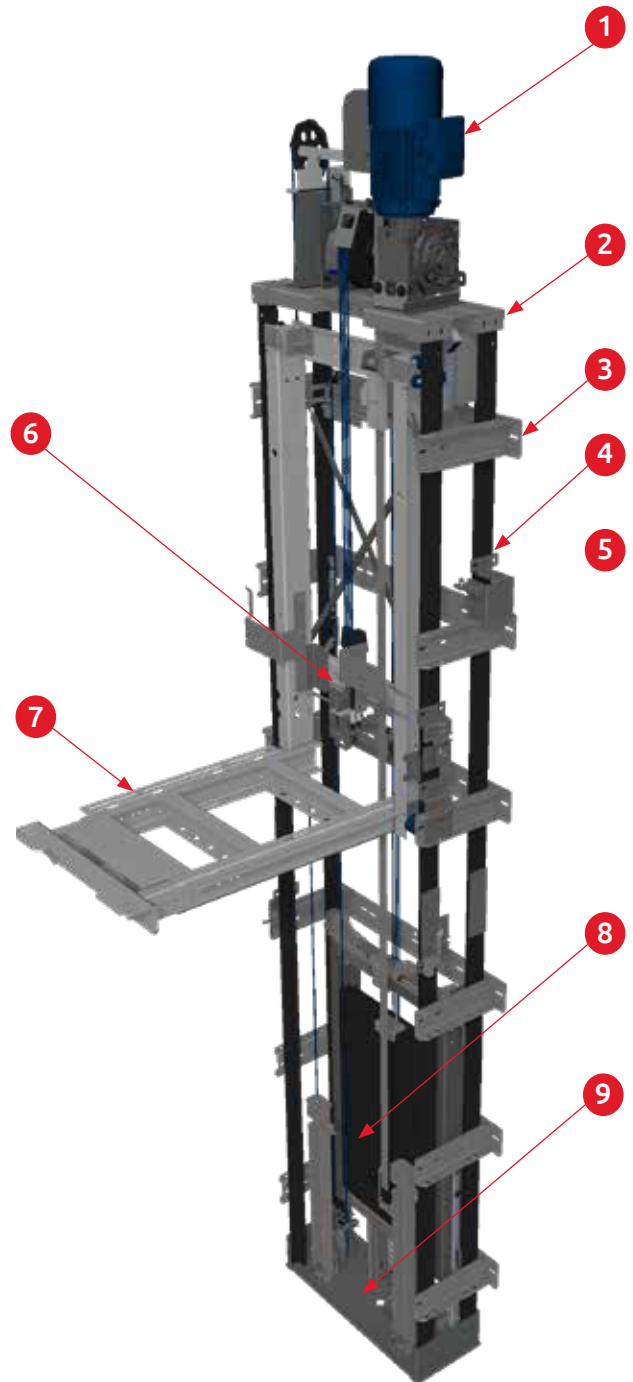

# Hoistway Construction

The walls of the elevator hoistway can be constructed of wood, poured concrete or concrete block. The wall behind the drive system (guide rails and motor head frame) must be load bearing and able to withstand the loads imposed by the elevator.

The guide rails and motor head frame mount to the wall with steel brackets. These rail brackets are fastened to the load bearing wall at preset locations.

The rail bracket locations are determined during the design phase. The rail brackets are generally every 4' apart, measured vertically, depending on the load capacity, size of cab and travel height. Please see final elevator shop drawings for actual locations. All the walls of the hoistway, especially the wall behind the rails and the entrance walls, need to be flush and plumb from floor to ceiling to within  $\pm 1/8"$ . This is to allow for the required running clearances.

No light is required at the top of the hoistway as the car top is equipped with a standard caged light fixture for use by the mechanic during his maintenance visits. A light is required in the pit (see Construction of Pit for details).

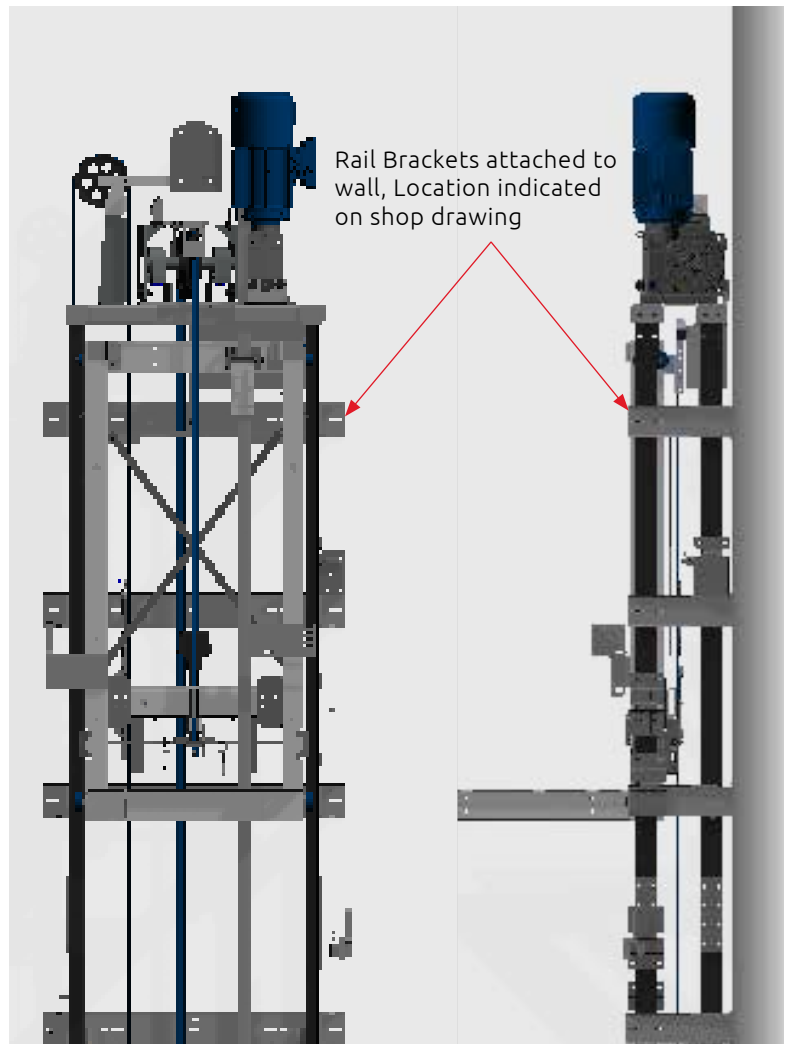

## Wood Construction

2" x 4" wood studs should be used, 2" x 12"s and 2" x 6"s (center) laid flat are then fastened between the studs. Consult with your local Garaventa Lift representative if you plan on using wood studs larger than 2" x 4", as this can affect clearances controlled by code.

The hoistway dimensions indicate the clear inside finished hoistway. Please ensure you allow for wall finishing (plywood/drywall) on top of the studs.

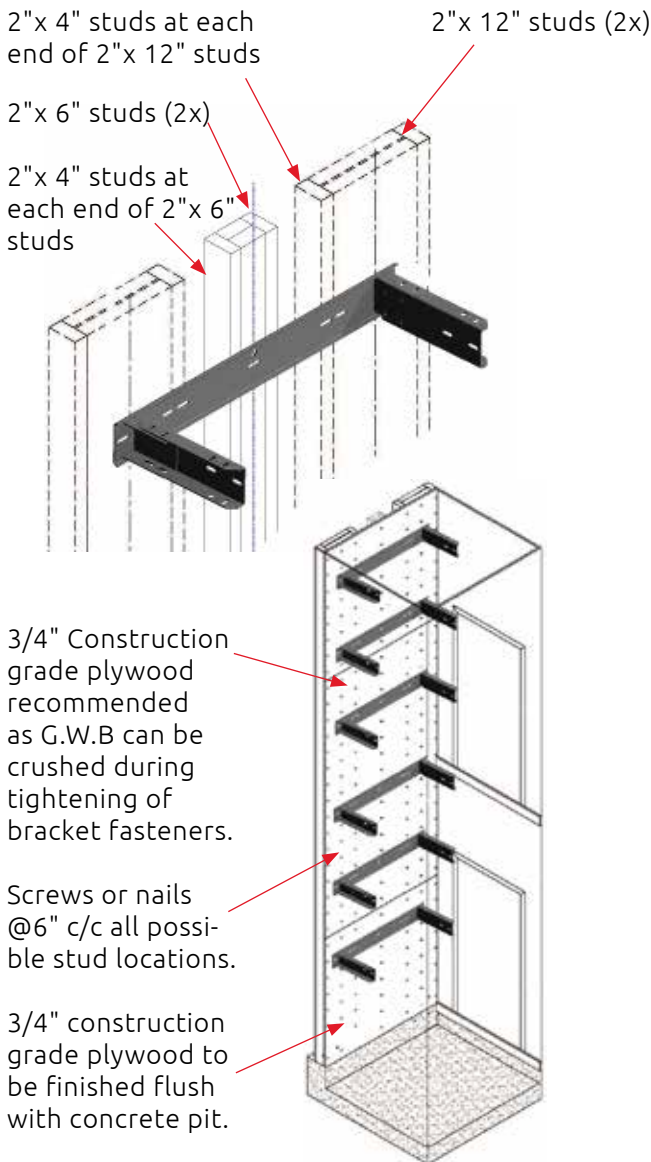

## Masonry Construction

It is not necessary to make the return walls on either side of the doors in concrete. More flexibility in door positioning during the installation can be achieved with wood framing around hoistway entrances.

## Door Openings

Garaventa Lift recommends that the walls on either side of the hoistway entrances be framed and finished after the doors and frames have been aligned on site. However a header frame above the door will be required to mount the door in place.

During installation the rail system and floor of the cab are installed, then the doors are aligned to the centerline of the cab opening.

It is preferable to fill concrete blocks with concrete

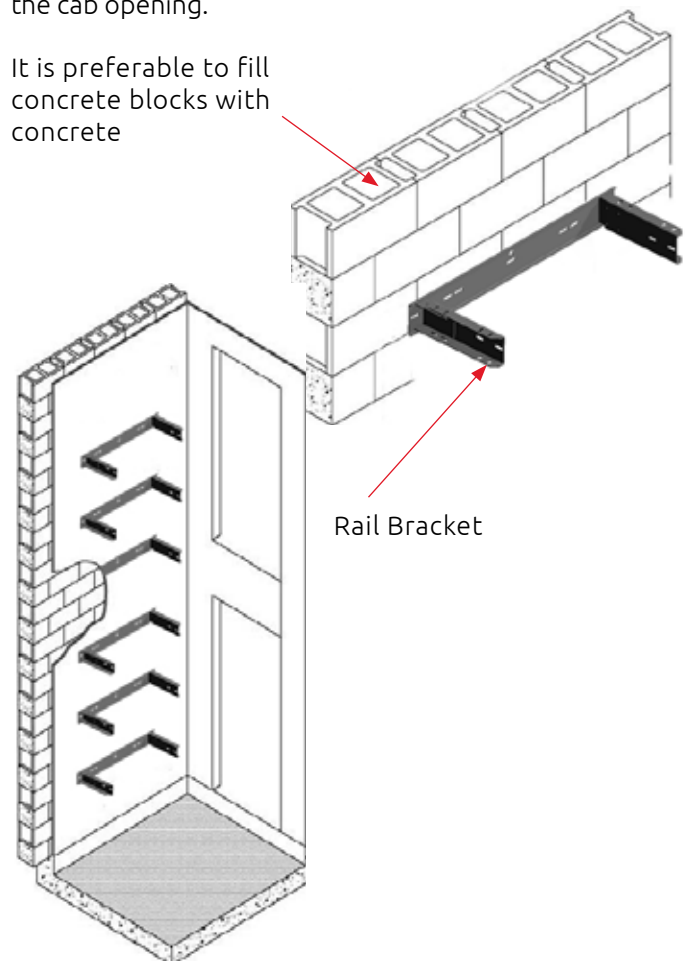

### NOTE: Typical construction shown.

A building structural engineer should be consulted to assure that the building and shaft will safely support all loads imposed by the elevator equipment.

# Construction of Pit

The pit must be the same width and length as the hoistway. Reactions are indicated on each project's shop drawings. A minimum 17" (432mm) **pit depth** is required.

Contact Garaventa Lift for pit depth less than 17".

A **pit ladder** is required only if the pit depth exceeds 35" (900mm). Consult your Garaventa Lift representative for details as changes to finished hoistway dimensions may be required.

## Pit Lighting

A **pit light** and **GFI duplex receptacle**, supplied by the General Contractor, are required in the pit of your Electric LULA for use by the mechanic during his maintenance visit. Consult Garaventa Lift dealer for location and routing of conduit.

Habitable space below hoistway will require the pit to be increased in depth to a minimum 19" (483mm) to accommodate the required **buffer springs**.

## Overhead Clearance

138" (3505mm) is required above the upper landing level finished floor to the ceiling above to meet the refuge space required by code. On existing construction, a **car top prop** can be used to reduce the overhead to 111" (2819 mm).

## Lifting Beam

A 4000 lb (1814kg) **Safe Working Load (SWL) beam** must be provided in the overhead. Beam to be positioned as shown in the elevation view. For overhead less than 138" (3505mm), the beam must be temporary. For overhead of 111" (2819 mm), position the underside of the beam, at 104" (2642 mm).

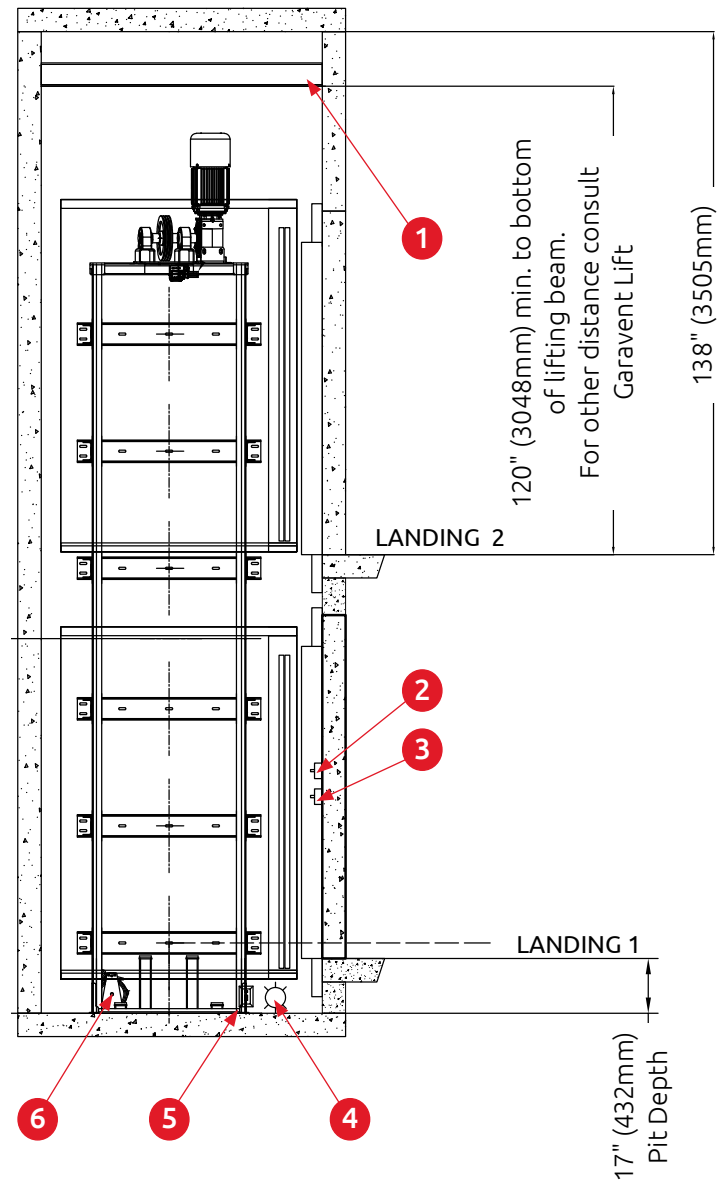

1. Lifting Beam min SWL 4000 lb (1814 kg)
2. Pit Stop Switch
3. Pit Light Switch (by others)
4. Pit Light - Guarded (by others)
5. Duplex GFI Receptacle (by others)
6. Speed Governor

# Loading Diagram

Rail reactions do not include safety factors. Applicable safety factors must be considered in hoistway design.

## Rail Brackets

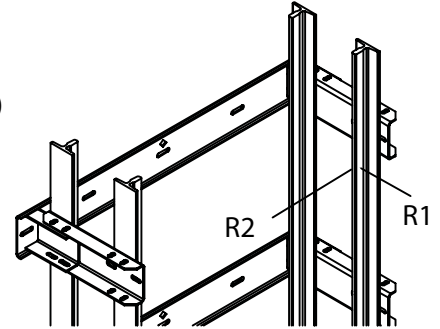
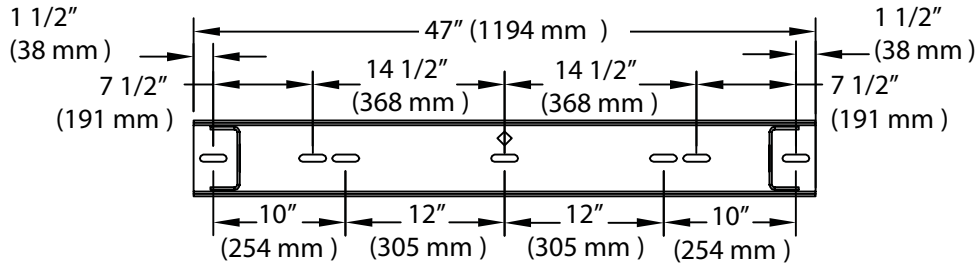

R1 load on each fixing point equals 466 lbf (2073 N) based on four mounting holes.

## Pit Plate Layout

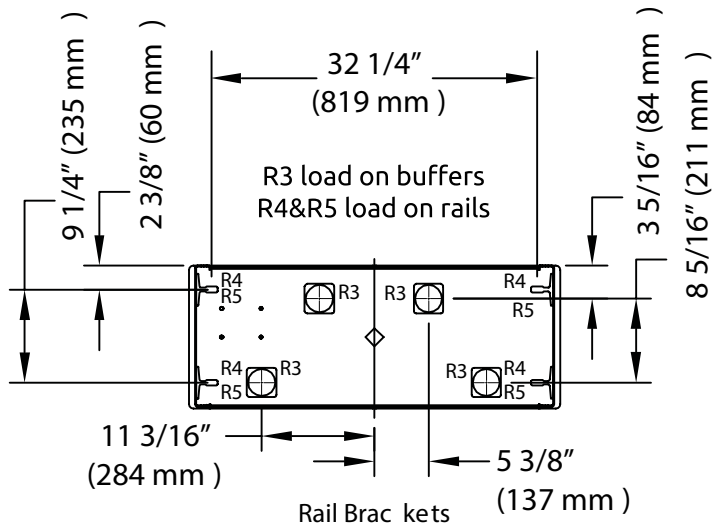

## Rail Forces

*R1	*R2
932 lbf (4146 N)	260 lbf (1157 N)
Rail Weight:	8.0 lbs/ft (12 kg/m)

## Vertical Pit Re-Action Force

R3	8000 lbs (3629 kg)	Per Load Point 2000 lbs (907 kg)
R4	3000 lbs (1361 kg)	Per Load Point 750 lbs (340 kg)
R5	9500 lbs (4309 kg)	Per Load Point 2375 lbs (1077 kg)



For total pull-out force on rail bracket, eg. 2 x 932 lbf (4146 N) = 1864 lbf (8292 N).



For local application of pit load, R1 must be doubled.



# Car Sizes and Configurations

The Electric LULA is available in 5 different configurations to suit your building. Each configuration has specific car sizes. Limited custom car sizes are available - please contact Garaventa Lift.

Style 1L	Style 1R	Style 2
		
Car Sizes:		
<p>48" x 54" (1220 x 1372 mm)</p> <p>42" x 54" (1067 x 1372 mm)</p> <p>42" x 60" (1067 x 1524 mm)</p>		<p>48" x 54" (1220 x 1372 mm)</p> <p>42" x 54" (1067 x 1372 mm)</p> <p>42" x 60" (1067 x 1524 mm)</p>

Style 3	Style 4
	
Car Sizes:	
<p>51" x 51" (1295 x 1295 mm)</p>	<p>51" x 51" (1295 x 1295 mm)</p>

# Layouts and Clearances

## Style 1L & 1R

Cab Size: 48" x 54" (1220 x 1372 mm)  
 (Dimensions apply to both Style 1L and 1R, shown below Syle 1L)

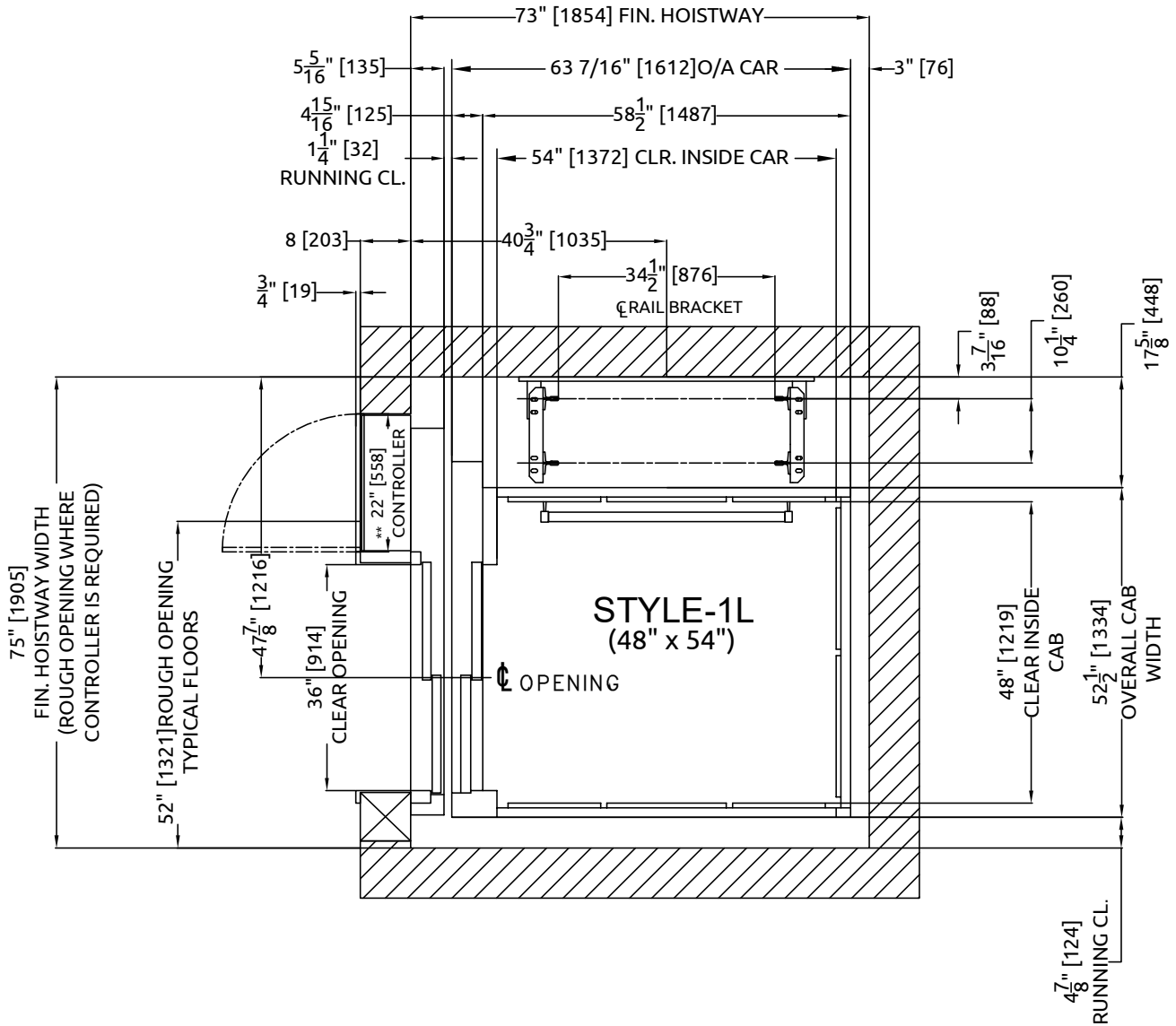

Dimensions shown are for **REFERENCE ONLY** and should not be used for site preparation or construction.

# Layouts and Clearances

## Style 1L & 1R

Cab Size: 42" x 54" (1067 x 1372 mm)  
 (Dimensions apply to both Style 1L and 1R, shown below Style 1L)

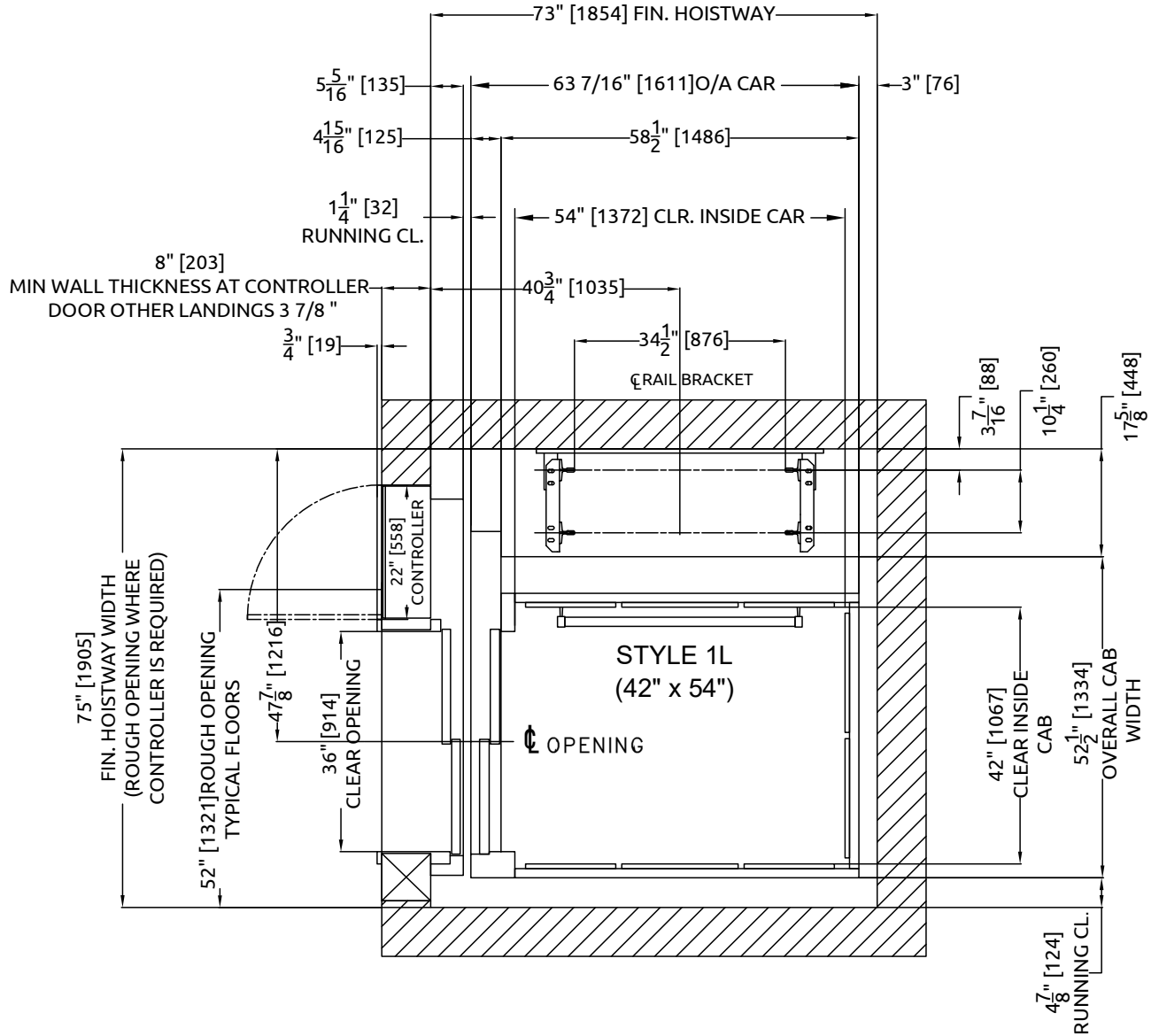

Dimensions shown are for **REFERENCE ONLY** and should not be used for site preparation or construction.

# Layouts and Clearances

## Style 1L & 1R

Cab Size: 42" x 60" (1067 x 1524 mm)  
(Dimensions apply to both Style 1L and 1R, shown below Syle 1L)

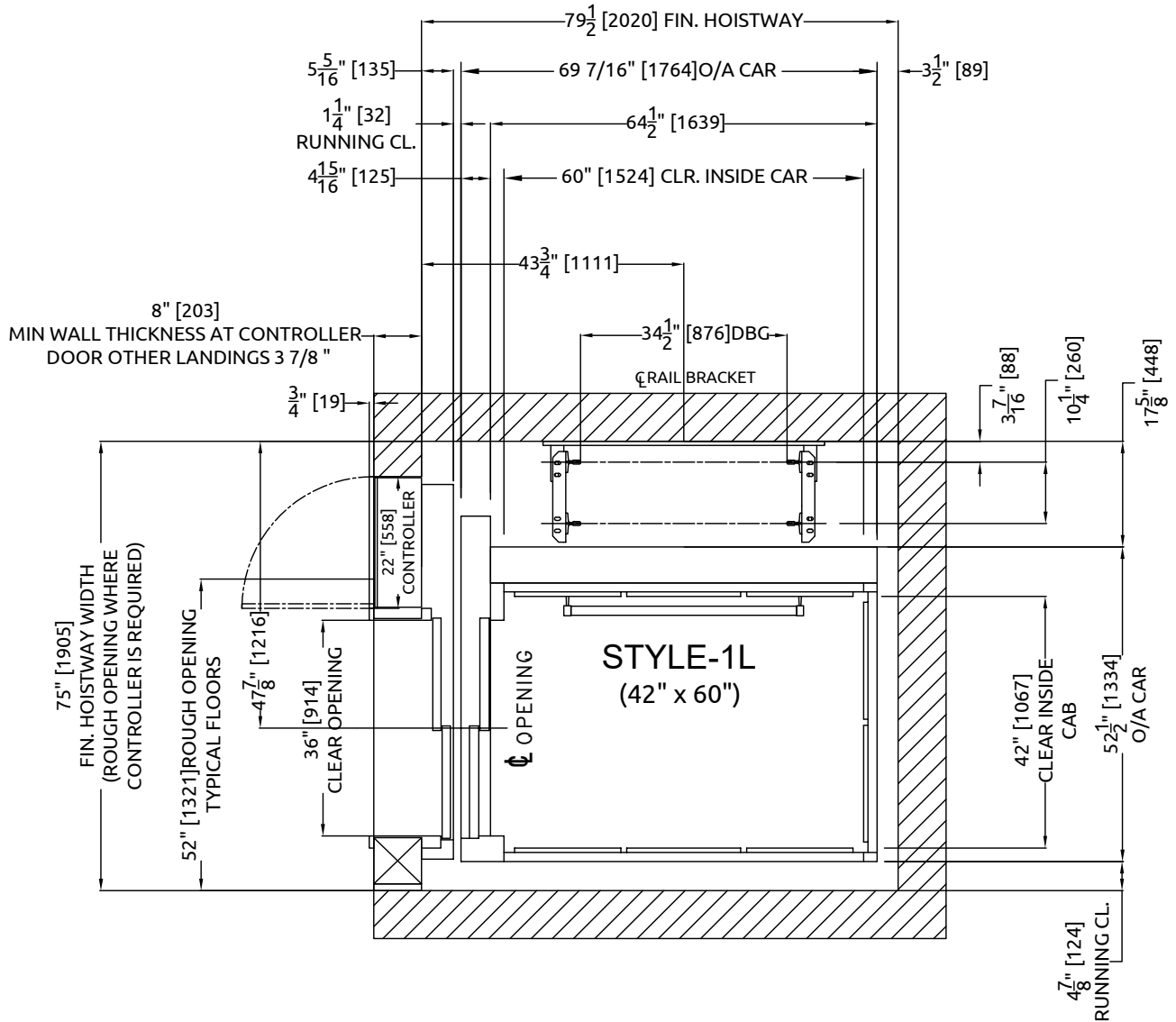

Dimensions shown are for **REFERENCE ONLY** and should not be used for site preparation or construction.

# Layouts and Clearances

## Style 2

Cab Size: 48" x 54" (1220 x 1372 mm)

**Note:** Controller can be installed on opposite door.

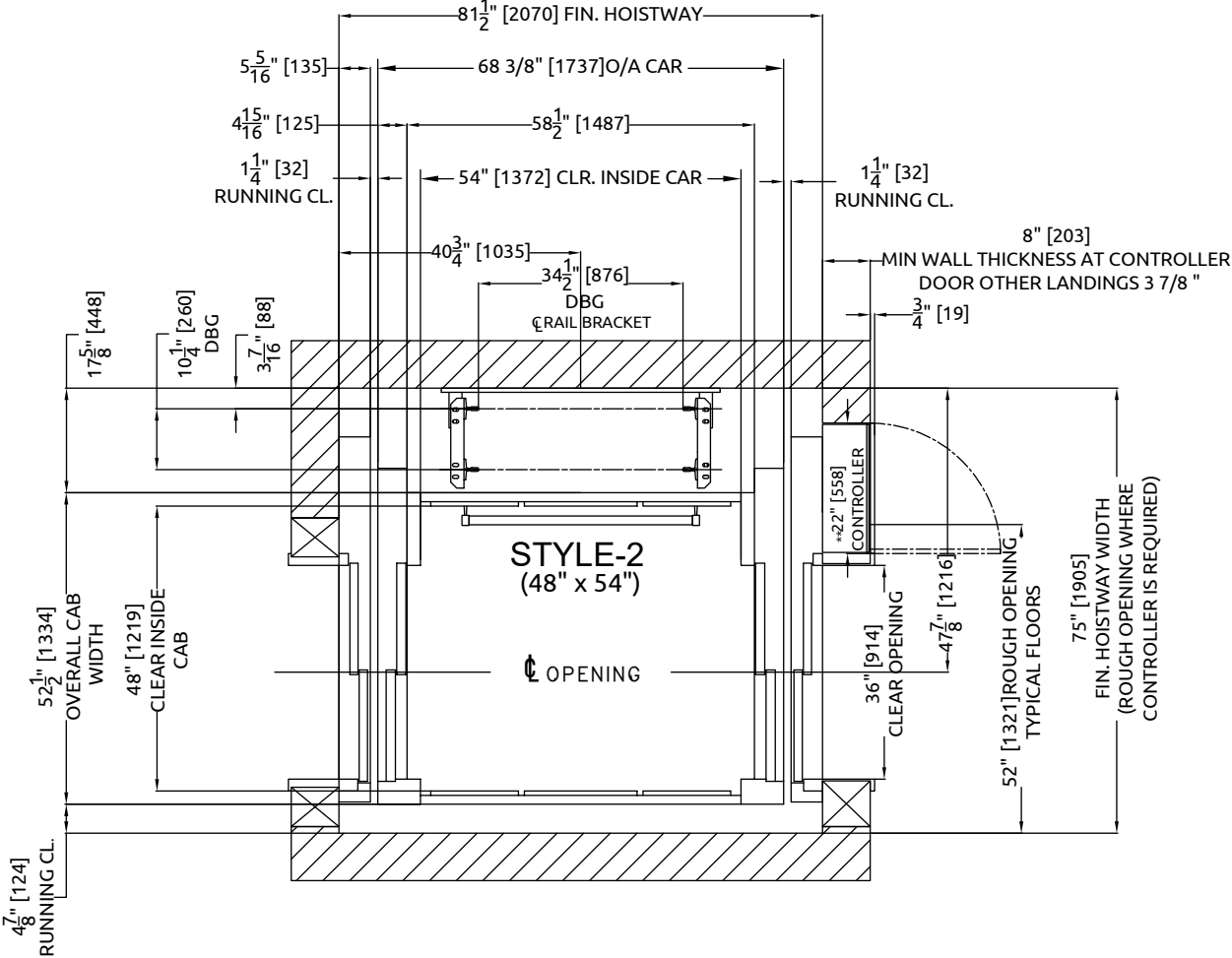

Dimensions shown are for **REFERENCE ONLY** and should not be used for site preparation or construction.

# Layouts and Clearances

## Style 2

Cab Size: 42" x 54" (1067 x 1372 mm)

**Note:** Controller can be installed on opposite door.

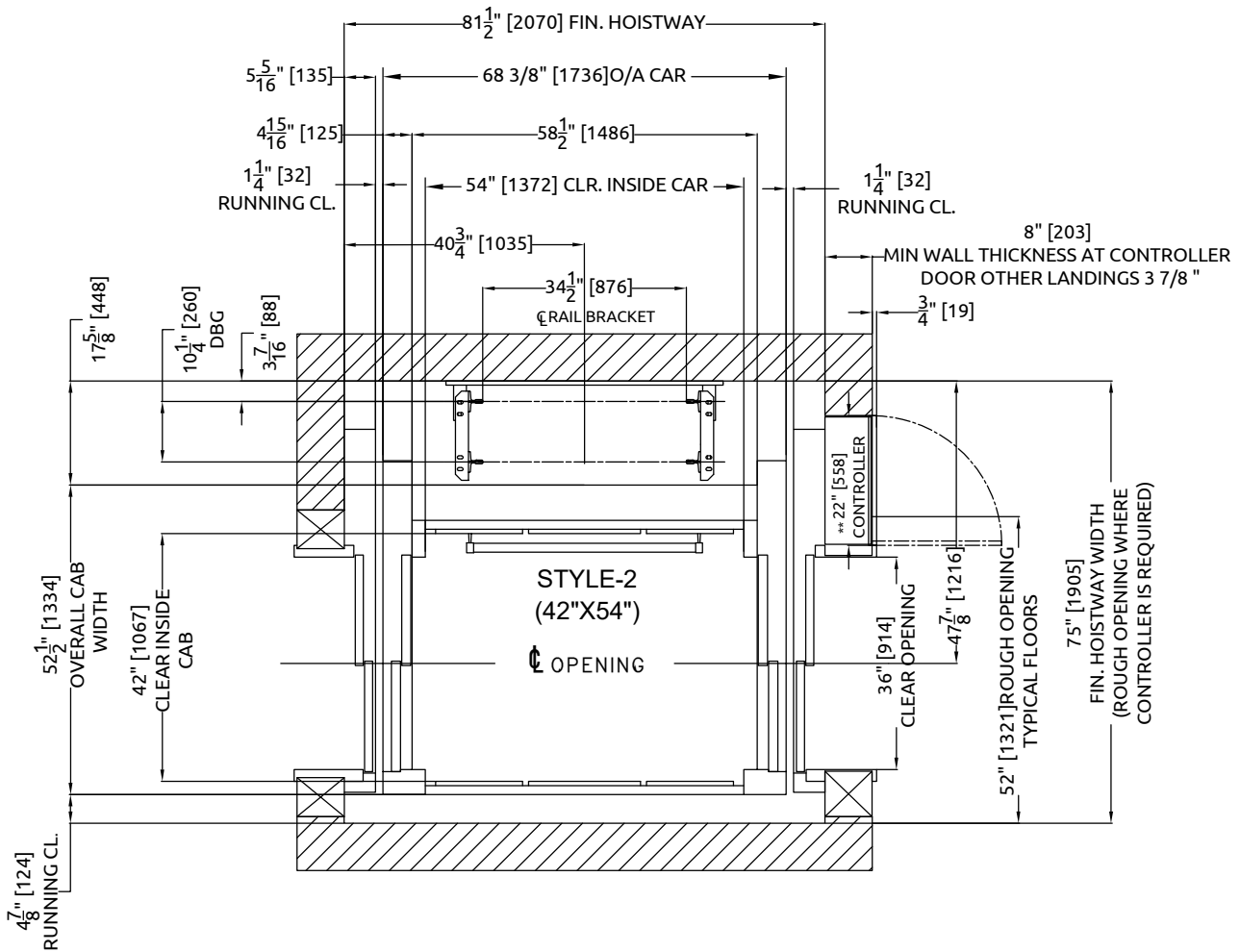

Dimensions shown are for **REFERENCE ONLY** and should not be used for site preparation or construction.

# Layouts and Clearances

## Style 2

Cab Size: 42" x 60" (1067 x 1524 mm)

**Note:** Controller can be installed on opposite door.

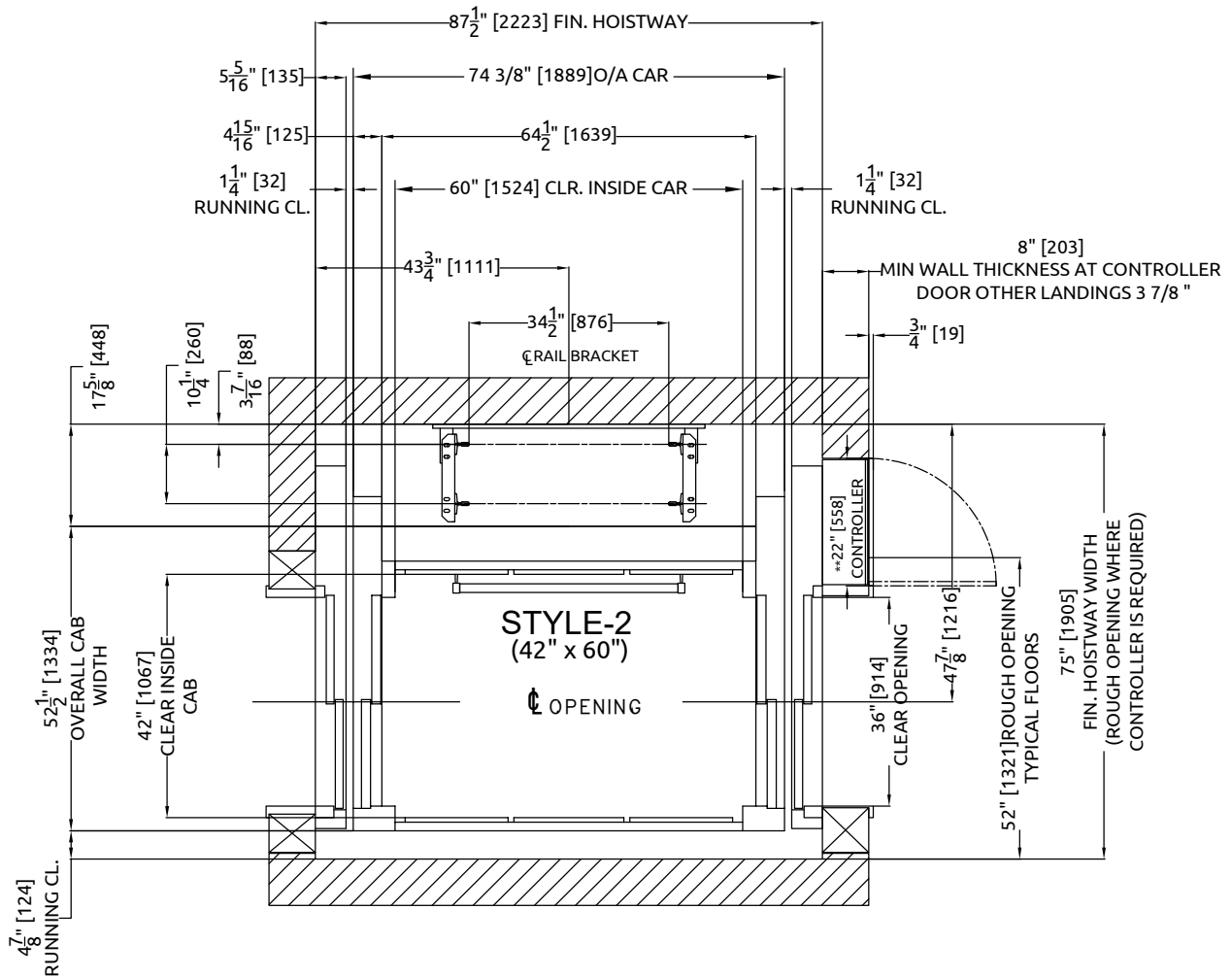

Dimensions shown are for **REFERENCE ONLY** and should not be used for site preparation or construction.

# Layouts and Clearances

## Style 3

Cab Size: 51" x 51" (1295 x 1295 mm)

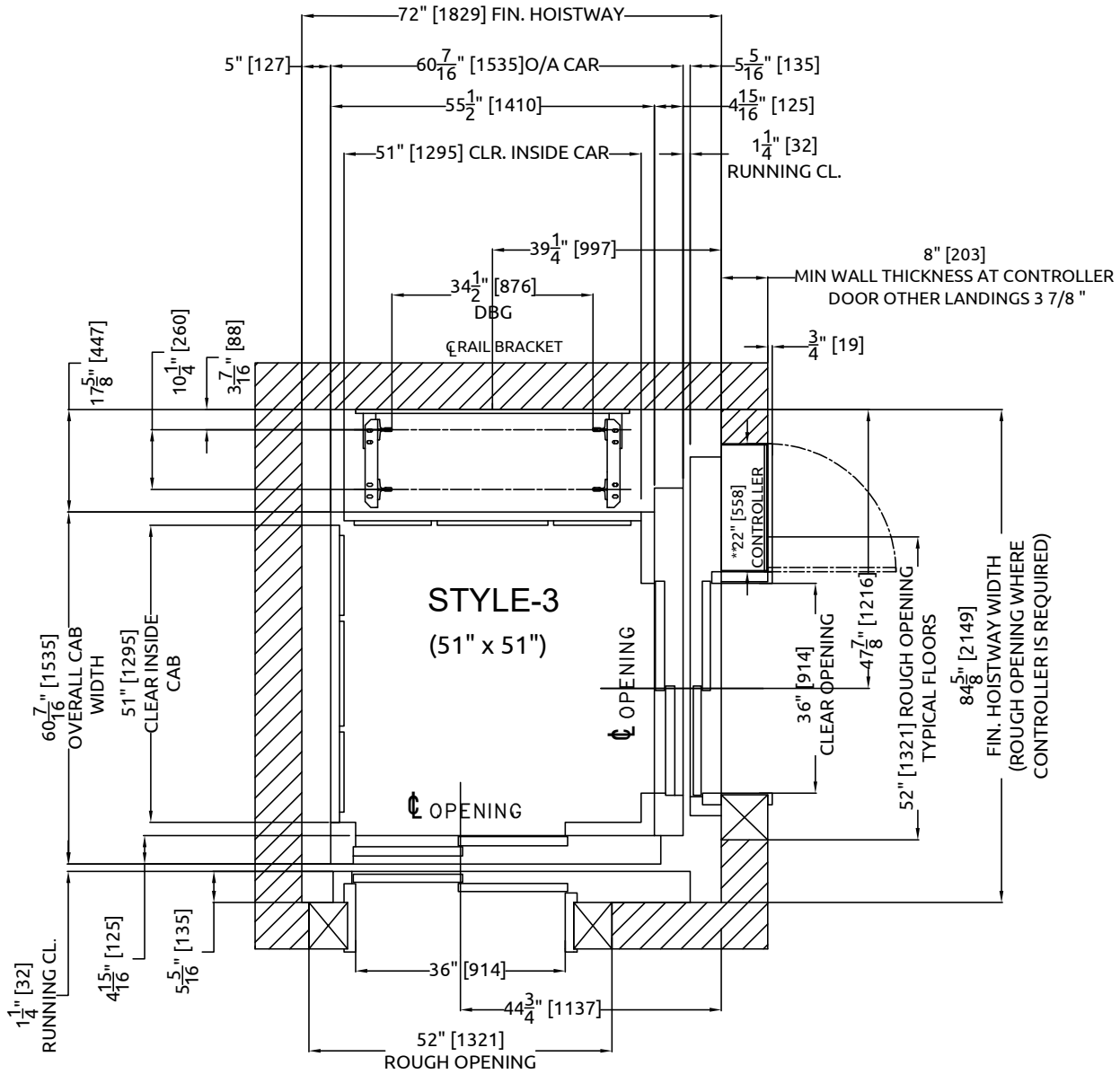

Dimensions shown are for **REFERENCE ONLY** and should not be used for site preparation or construction.



# Layouts and Clearances

## Style 4

Cab Size: 51" x 51" (1295 x 1295 mm)

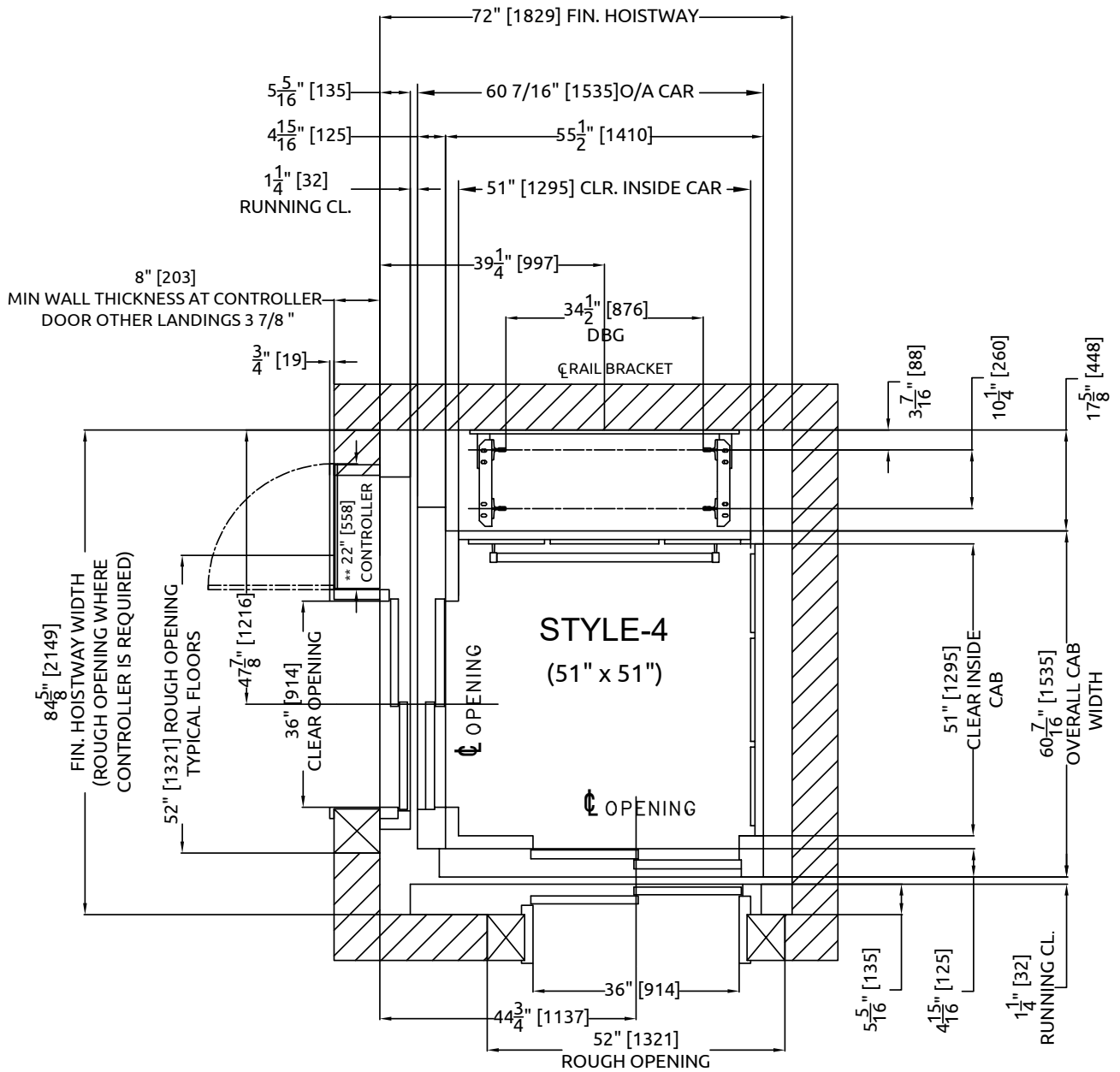

Dimensions shown are for **REFERENCE ONLY** and should not be used for site preparation or construction.

# Operating Controls

The controls of the Electric LULA are the same as would be found on a commercial elevator. Operation is fully automatic.

Braille Markings for the COP, Hall Stations and Hall landings are included as standard equipment.

## Car Operating Panel (COP)

The Electric LULA's COP is equipped with a digital floor indicator, illuminated floor buttons, alarm button, door open and door close buttons and a keyed emergency stop switch. An integrated hands free phone is required.

## Hall Stations

The Hall Station buttons illuminate when pushed. The push button itself is always made of stainless steel for maximum durability. For increased safety and security, an optional key switch allows the entire elevator to be deactivated.

## Car Direction Lantern

Mounted in the car to the car slam post opposite the COP, the Car Direction Lantern is an audio and visual signaling device that indicates direction of travel and arrival at the floor.



# Entrance and Car Doors

The Electric LULA uses commercial elevator entrance and car doors. When open the doors provide a 36" (915mm) x 80" (2032mm) clear opening. They are two-speed horizontal sliding doors and are equipped with full height photo-electric presence/obstruction sensors.

The hall entrances have an hour and a half fire rating, and are prime finished, ready to be painted to match your building décor. The car doors are finished to match your car wall trim. All doors can be supplied in brushed stainless steel.



# Controller

The control box is available in two sizes:

- Small Box in Machine Room (Pos. 6):
- Slim Box in Door Buck (shown below):

## Electrical Disconnects

In the machine room you will need to provide two lockable fused disconnects – one 15 amp for lighting and one 40 or 30 amp for the drive motor (depends upon site voltage). Disconnect switches should be located on the strike (lock) side of the machine room door. In accordance to the electrical code, you must provide a minimum of 36" (915mm) in the United States and 39 3/8" (1000mm) in Canada of working space in front of each disconnect switch.

The main disconnect switch for the machine unit requires an auxiliary contact.

The fused disconnect switch rating and fuse rating for the lift will be shown on the shop drawings for your project.

At least one GFCI duplex receptacle connected to a 15 amp branch circuit shall be installed in the door buck cabinet.

## Ventilation Requirements

No special requirements. The elevator drive unit will generate approximately 3200 BTU per hour under normal operating conditions. Recommended temperature for elevator equipment is 50° – 90° F (15° – 32° C) and 5% – 90% non-condensing.

## Mains Power Requirements

The motor can be ordered to suit either three phase or single phase power.

- Standard: 208 VAC Three phase 30 amps
- Optional: 230 VAC Single phase 40 amps

## Emergency Battery Lowering

In case of a power outage the elevator is provided with a second power source that allows the car to be lowered to the lowest landing. While descending, the car can stop and the passenger can exit the car on any landing along the way.

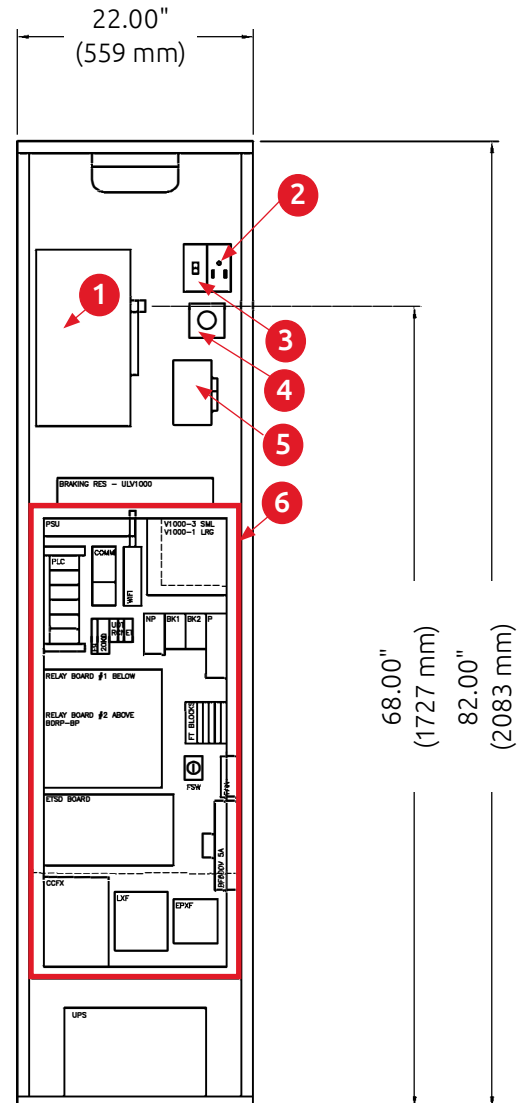

1. Main Disconnect
2. GFCI Receptacle
3. Light Switch
4. Stop Switch
5. Lighting Disconnect
6. Inside Controller Cabinet

# Door Details

## Wood and Drywalls

Garaventa Lift recommends that the walls on the entrance side of the hoistway be left open until the door frames are set. This allows the doors to be aligned with the centerline of the car. Contact your local authorized Garaventa Lift representative for further details.

### STANDARD FEATURES

FRAMES:	SQUARE PROFILE, KNOCKED DOWN CONSTRUCTION
SILLS:	EXTRUDED ALUMINUM
DUST COVER:	HIGHEST LANDING
TOE GUARD:	LOWEST LANDING

NOTE: BACKING FOR ANCHOR BOLTS SUPPLIED BY OTHERS

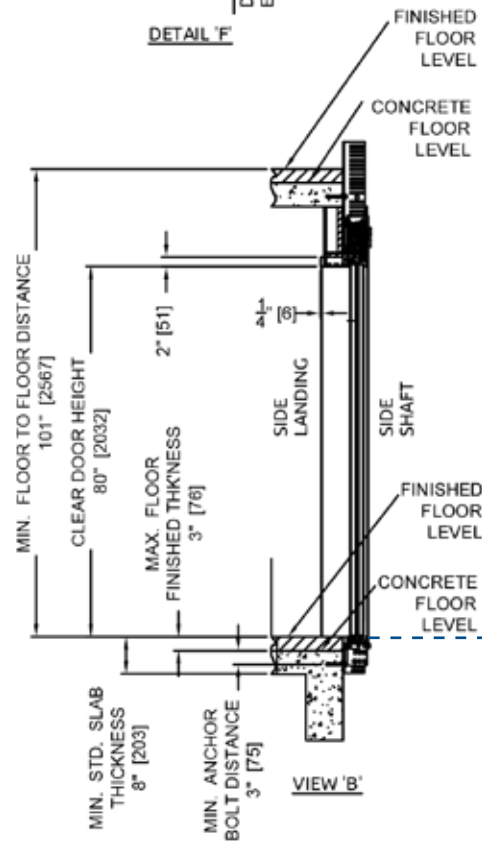
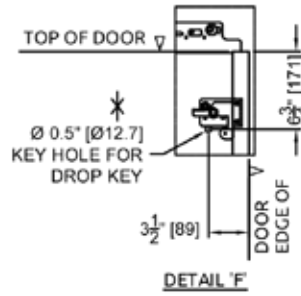
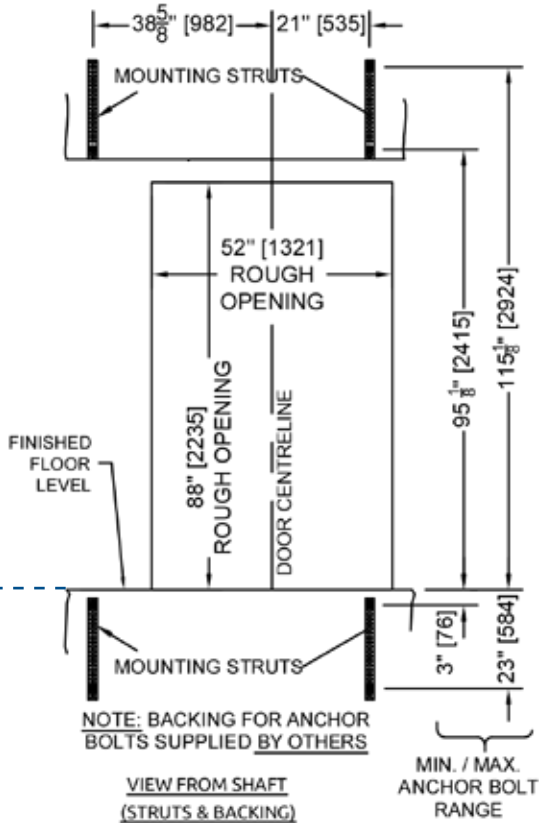

### NOTES:

DO NOT BUILD WALLS UNTIL DOOR FRAMES AND SILLS ARE IN PLACE. LEAVE ROUGH OPENINGS AS SPECIFIED ON PLAN VIEW.

DRYWALL AND MASONRY WORKS BY OTHERS

STANDARD FRAME POST DIMENSION 'FP' 5 7/8" [149]

STANDARD WALL DEPTH DIMENSION 'WD' 3 7/8" [98]

COMBINATION DRYWALL / MASONRY JAMB: UL "B" APPROVED 1 1/2 HR.

KEY HOLE FOR DROP KEY DRILLED BY OTHERS WHERE PERMITTED

# Door Details

## Wood and Drywalls

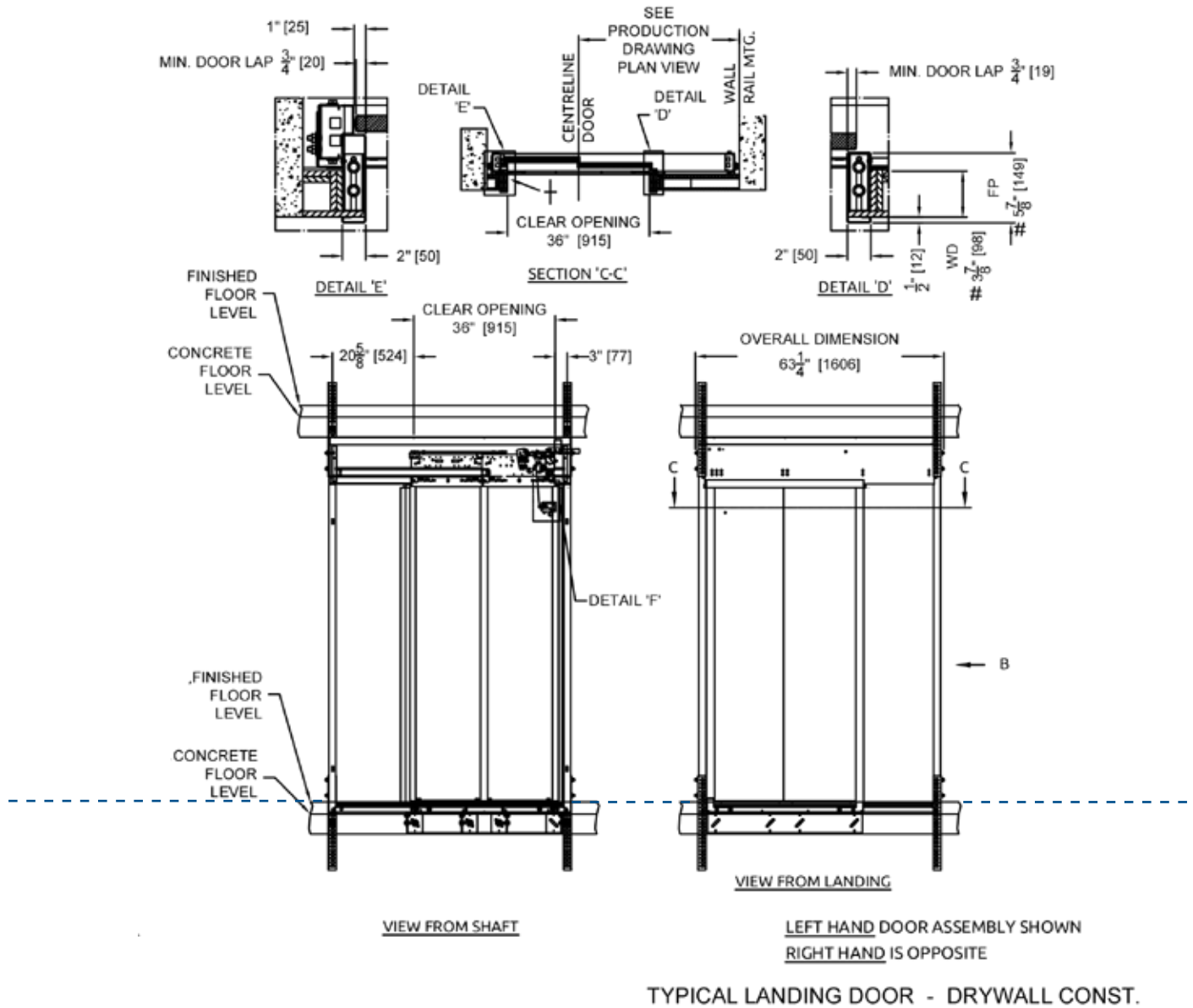

See layouts and clearances for door centerlines.

# Door Details

## Masonry Walls (with Controller in Door Buck)

Garaventa Lift recommends that the walls on the entrance side of the hoistway be left open until the door frames are set, or a rough opening can be left to accommodate for the doors to be placed to allow for proper door alignment with the elevator. Contact your local authorized Garaventa Lift representative for further details.

### STANDARD FEATURES

FRAMES:	SQUARE PROFILE, KNOCKED DOWN CONSTRUCTION
SILLS:	EXTRUDED ALUMINUM
DUST COVER:	HIGHEST LANDING
TOE GUARD:	LOWEST LANDING

**NOTE: BACKING FOR ANCHOR BOLTS SUPPLIED BY OTHERS**

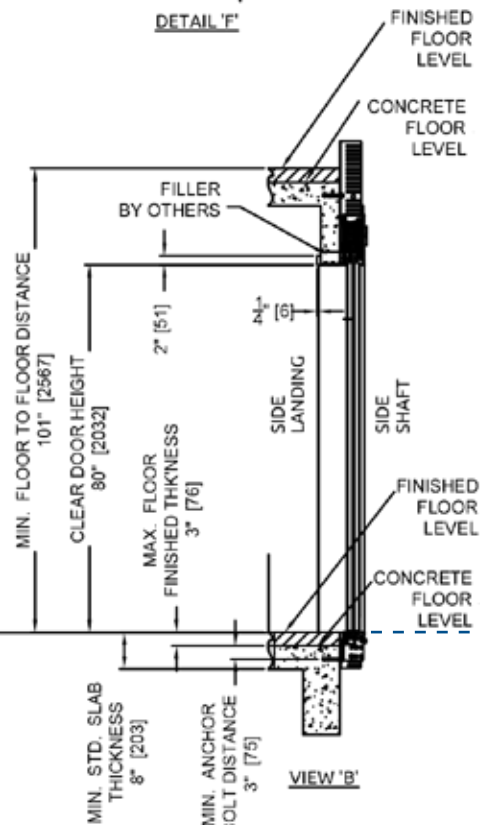
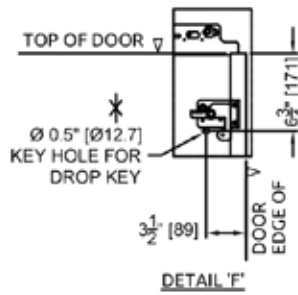
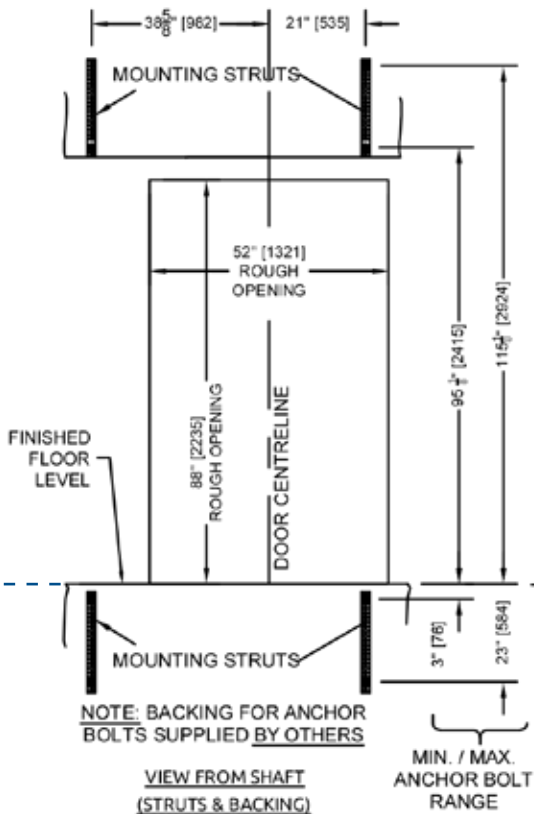

### NOTES:

- DO NOT BUILD WALLS UNTIL DOOR FRAMES AND SILLS ARE IN PLACE. LEAVE ROUGH OPENINGS AS SPECIFIED ON PLAN VIEW.
- DRYWALL AND MASONRY WORKS BY OTHERS
- # STANDARD FRAME POST DIMENSION 'FP' 5 7/8" [149]
- STANDARD WALL DEPTH DIMENSION 'WD' 3 7/8" [98]
- † COMBINATION DRYWALL / MASONRY JAMB: UL 'B' APPROVED 1 1/2 HR.
- \* KEY HOLE FOR DROP KEY DRILLED BY OTHERS WHERE PERMITTED

### JOB SPECIFIC FEATURES

FINISH (PANELS):	BAKED ON PRIMER (GREY)
FASCIA:	46" WIDE
BY: OTHERS	
DOOR HANDING:	QTY.
RIGHT HAND:	<input type="text" value="0"/>
LEFT HAND:	<input type="text" value="2"/>

# Door Details

## Masonry Walls (with Controller in Door Buck)

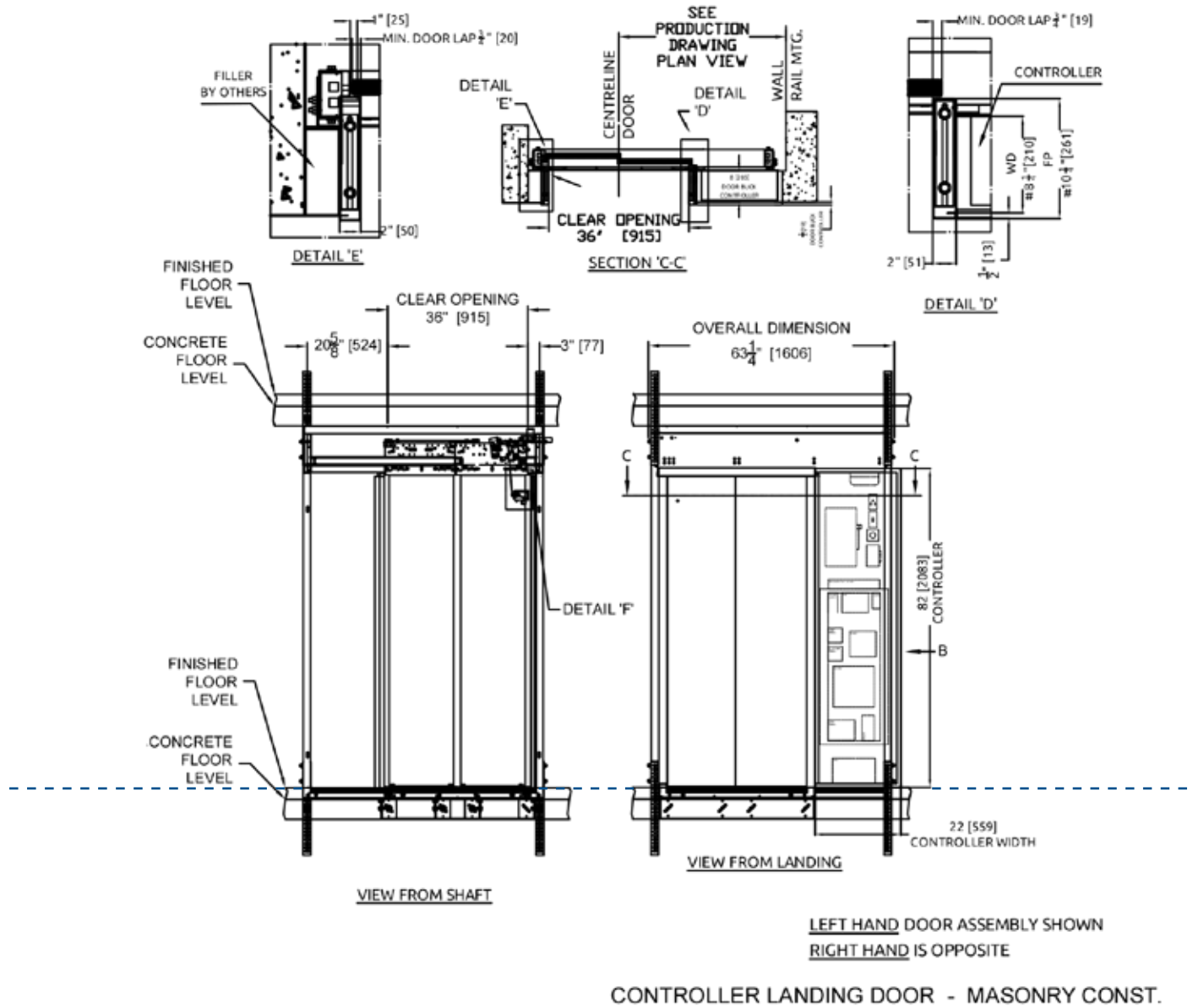

See layouts and clearances for door centerlines.

# Technical Information

## Car Sizes

- 48" x 54" (1220 x 1372mm) Style 1 + 2 only
- 42" x 54" (1067 x 1372mm) Style 1 + 2 only
- 42" x 60" (1067 x 1524mm) Style 1 + 2 only
- 51" x 51" (1295 x 1295mm) Style 3 + 4 only

## Rated Load

- 1400 lbs (635 kg)

## Speed

- 30 fpm (0.15 m/s) nominal speed
- Optional 40 fpm (0.2 m/s)

## Travel Range

- 25 ft (7.6 meters)
- Optional 30 ft (9 meters)

## Pit Depth

Recommended pit depth of 17" (432 mm), Pit Prop standard equipment with elevator.

## Overhead Clearance (Refuge Space)

- 138" (3505mm) standard overhead
- 111" (2819mm) min. overhead in existing construction with the use of a Car Top Prop
- Lifting Beam required

## Drive System

- Counterweight traction with slack cable safety device
- Geared motor 1:1 sheave
- Three 3/8" diameter steel cables
- Rope wedge sockets

## Daily Cycles

The elevator is designed based on the following daily cycles:

- Normal 200
- Heavy 300
- Excessive 450
- Max. starts per hour 45

Consult your Sales Representative if there is a chance you may exceed these amounts.

## Power Supply

Elevator:

- Standard: 208 VAC three phase, 30A, 60Hz
- Optional: 230 VAC single phase, 40A, 60Hz

Lighting:

- 110 VAC single phase, 15A

## Stops

- Up to 6 stops

## Controls

- Fully automatic push button operation,
- PLC Controller,
- Integrated self-diagnostics,
- Digital floor indicator in car,
- Automatic car lighting upon entry,
- Illuminated push buttons,
- Car arrival lanterns in car door jamb.

## Doors

36" x 80" (914 x 2032mm) two-speed horizontal sliding hoistway doors (with 1.5 hour fire rating) and car doors.

## Safety Features

- Uninterruptible Power Supply (UPS) emergency backup power lowering system,
- Emergency manual lowering system,
- Bi-directional Safety brake system,
- 2 speed door operators with integral gate switch,
- Automatic bi-directional floor leveling,
- Emergency alarm button in car,
- Emergency keyed stop switch in car,
- Final limit switch.

## Unique Standard Features

- Braille markings,
- Car direction lantern comes with audio and visual signals,
- Full height photo-electric presence/obstruction sensors,
- Automatic home park feature,
- Integrated hands free telephone.

## Code Compliance

- ASME A17.1, Section 5.2 LU/LA Elevators
- CSA B-44, Section 5.2 LU/LA Elevators
- ADA (Americans with Disabilities Act)

## Popular Options

- Phone monitoring
- Custom car finishes,
- Additional handrails,
- Fireman service (Phase 1),
- Buffer springs (increases your pit depth),
- Keyed hoistway access,
- Counterweight safeties.



